

Nivel medio mayor – Lenguaje verbal.

Act.: Responde quiénes son y que hacen. Recorta y pega los elementos que le corresponden a cada trabajador (doctor, bombero, carabinero). Completa la frase.



El es un _____

El es un _____





El es un _____

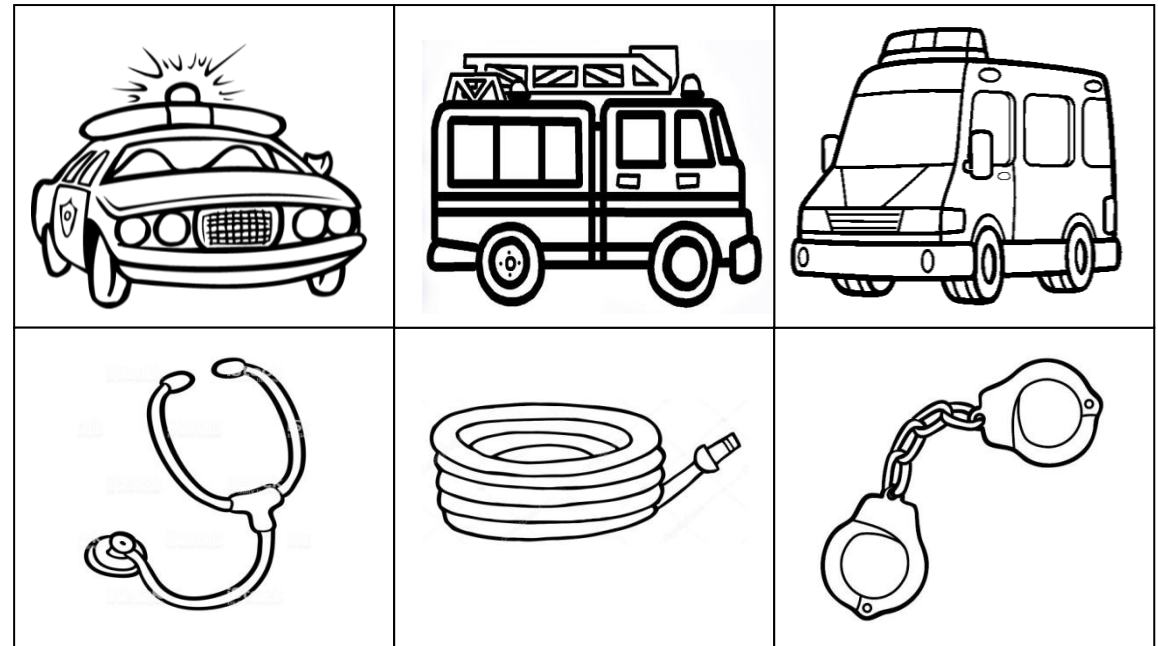

Nivel medio mayor – Lenguaje verbal.

Act.: Pinta y recorta las tarjetas (las pueden pegar sobre cartón). Nombra y muestra los trabajos y elementos (profesora, enfermera, peluquero, cocinero, mecánico, olla, secador de pelo, pizarra, llave, jeringa). Junta a cada trabajador con el elemento que corresponda.

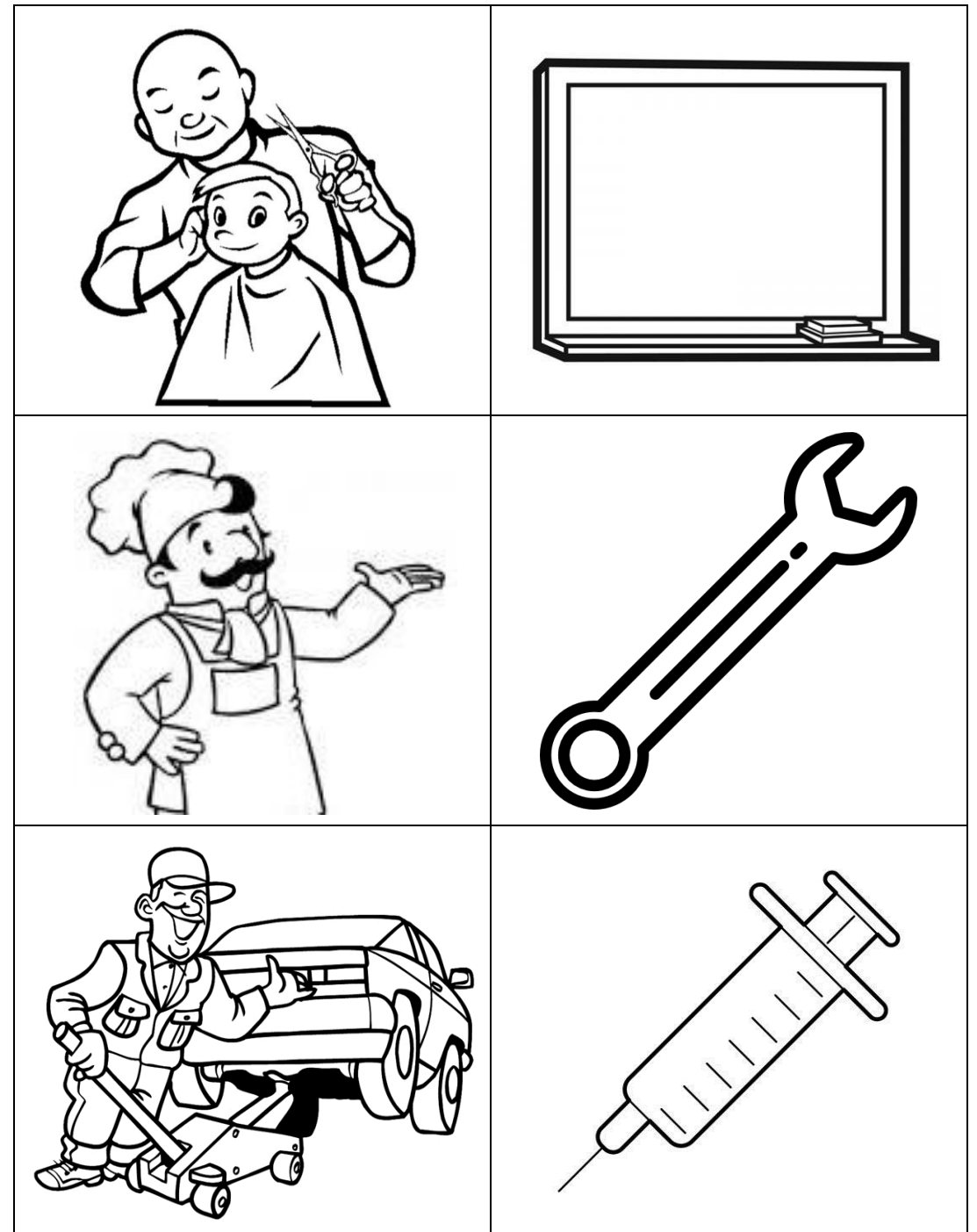
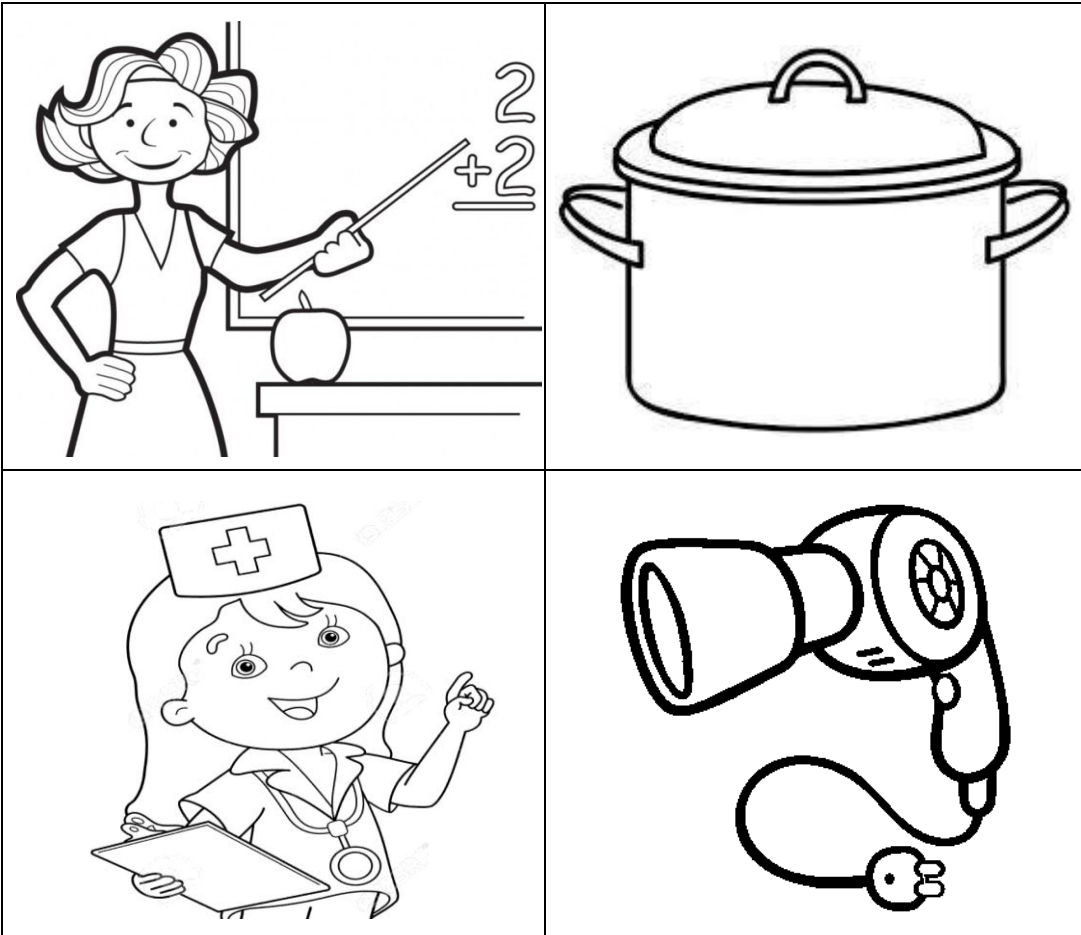

Nivel Medio Mayor-Lenguaje escrito.

Actividad: Pinta o rellena el camino (sin salirte) que debe seguir cada carro para apagar el fuego.



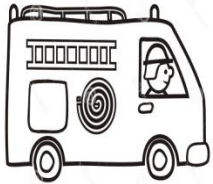

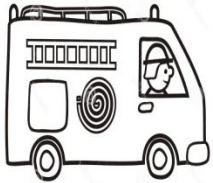

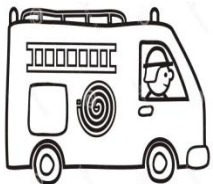





Pinta y decora.

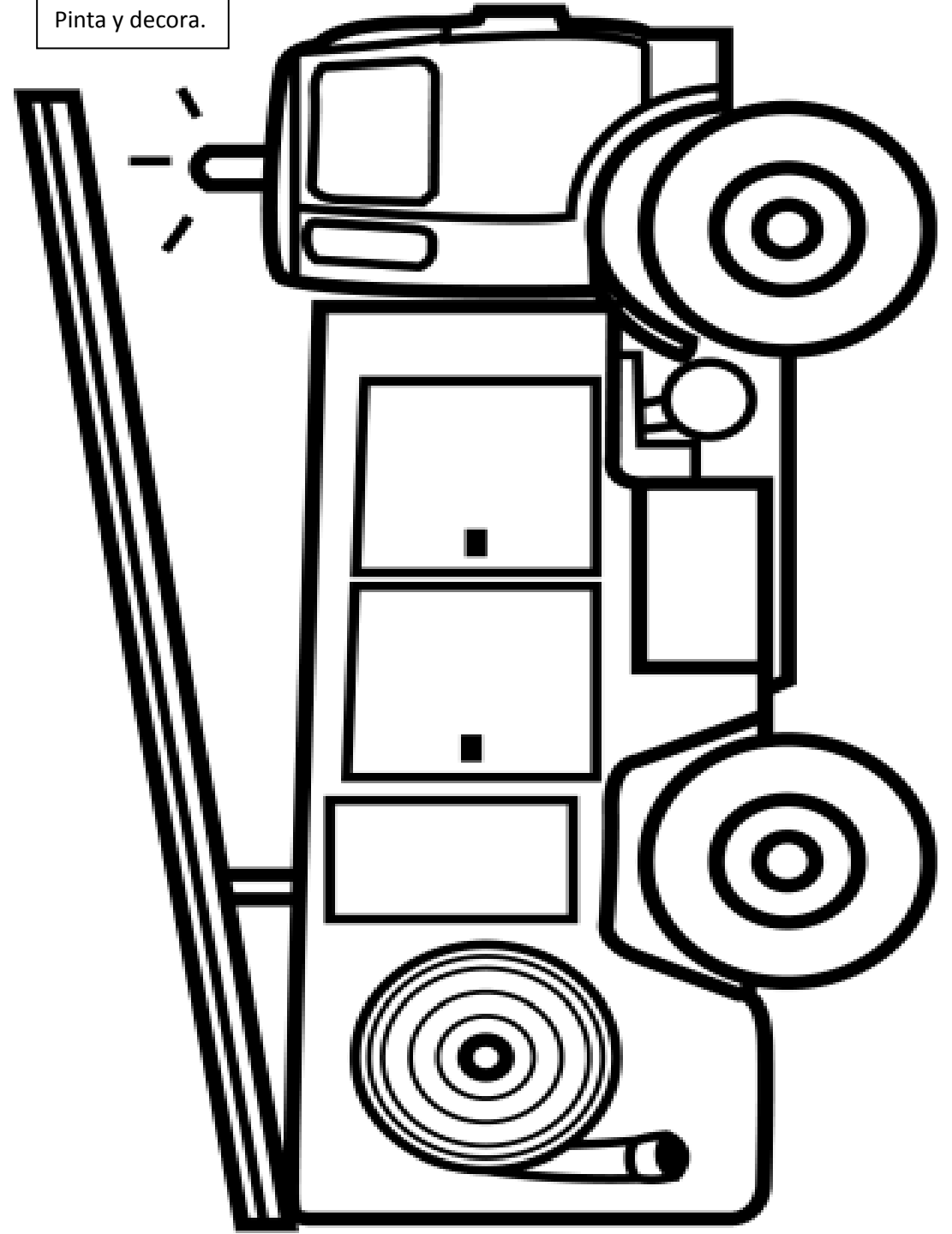

Nivel medio mayor – Plan Especifico

Act: En cada fila muestra y pinta solo los dibujos que nombran tus padres.

Pez-pulpo-estrella

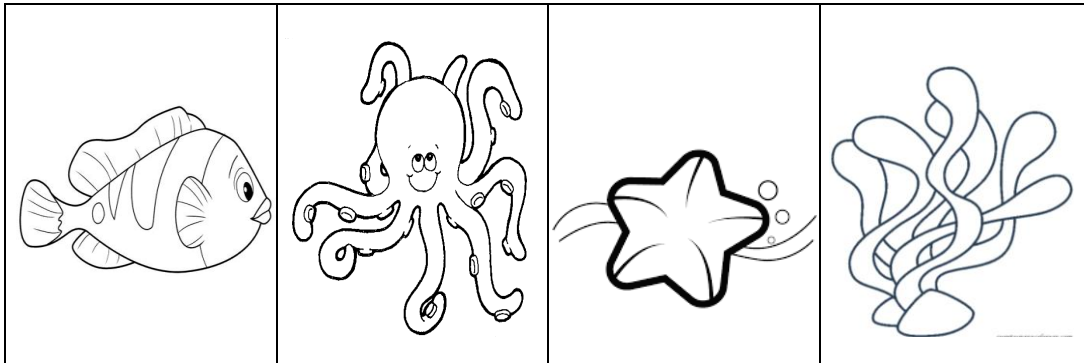

Ballena-delfín-tortuga

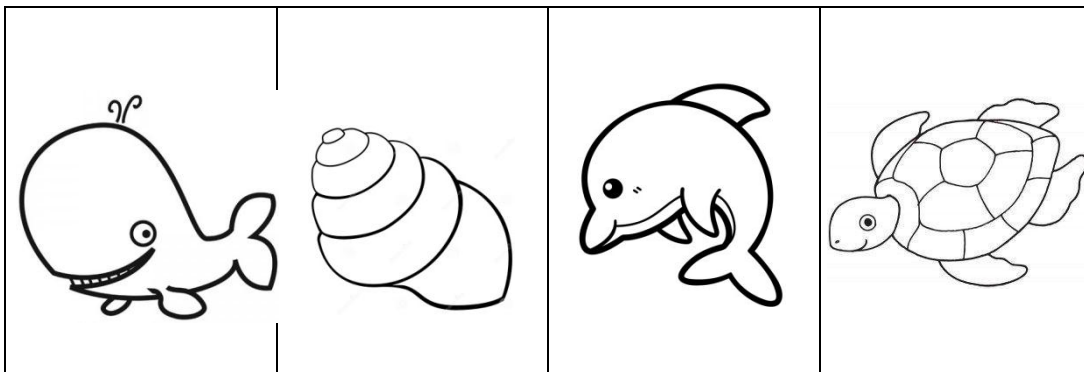

Cangrejo-tiburón- foca

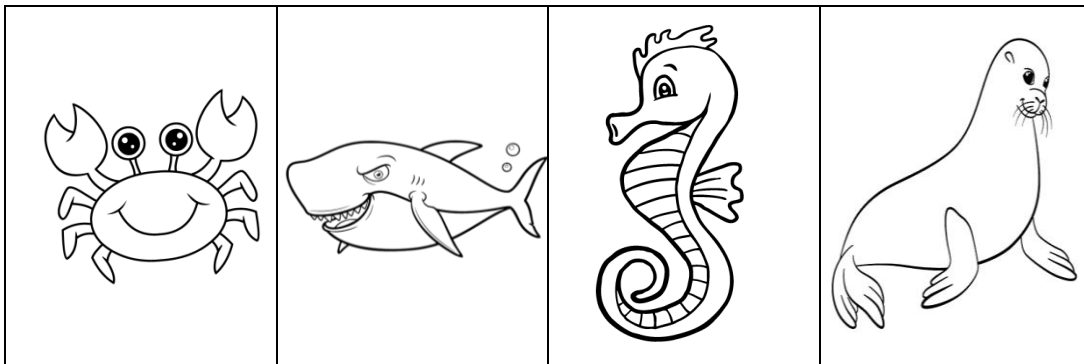

Nivel medio mayor – Plan Especifico

Act: A continuación escucharas una secuencia de palabras, primero 1, luego 2 y finalmente 3. Escucha y luego repite cada secuencia sin mirar las imágenes.

